

MAIN FEATURES

AISI 316 stainless steel construction

For off-shore and industrial applications

Weatherproof standard IP66/IP67

Standard preset option

DESCRIPTION

Electropolished stainless steel Pan & Tilt unit designed for movement on horizontal and vertical axis.

The NXPTH, together with the stainless steel housings, is built to resist the most severe environments. It is developed for the offshore market, for every type of sea-going vessel and industrial applications.

Each detail has been carefully analysed, resulting a reliable product suitable for highly corrosive environments. The accurate mechanical construction and reliable motors utilized reduce the need of maintenance even in situations of heavy mechanical stress.

The NXPTH allows a maximum horizontal/vertical rotation of 340° and is equipped with potentiometers which allow the preset function.



NXPTH



NXPTH + NXMK + VIPNX

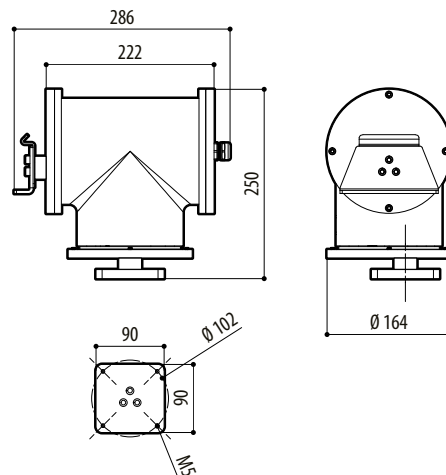

NXPTH

AVAILABLE MODELS			
Code	Power supply	Preset	Max consumption
NXPTH210	230Vac	•	26W
NXPTH211	24Vac	•	26W

TECHNICAL DATA

GENERAL

Constructed from electropolished stainless steel (Austenitic alloy stainless steel, corrosion and heat resistant according to the following standards):

- UNI 6900-71: X 2 Cr Ni Mo 17 12
- AISI: 316
- DIN 17006: X 2 Cr Ni Mo 18 10
- N° WERKSTOFF: 1.4404
- AFNOR: Z2 CND 17-12
- BSI: 316 S 12

The screws utilised are in austenitic alloy stainless steel, corrosion and heat resistant according to the following standards:

- UNI 6900: X 5 Cr Ni Mo 1712
- AISI: 316
- ISO quality: A4
- Resistance class ISO: 80

Supplied with instruction manual and installation kit

UNI: Ente Nazionale Italiano di Unificazione, AISI: American Iron and Standard Institute, DIN: Deutsche Industrie Normen, AFNOR: Association Française de Normalisation, BSI: British Standard Institution, ISO: International Organization for Standardization.

MECHANICAL

Dimensions: 164x250x280mm (6.4x9.8x11in)

Maximum load: 40kg (88lb) (balanced)

2 PG13.5 cable glands in nickel-plated brass for external connections

External body polishing

O-ring gaskets

0-340° Horizontal movement

Horizontal speed 5°/s

Pan Dynamic Torque 35Nm at specified voltage

Pan Static Torque 12Nm

Horizontal limit switches, internally adjustable

0-340° Vertical movement

Vertical speed 3°/s

Tilt Dynamic Torque 60Nm at specified voltage

Tilt Static Torque 24Nm

Backlash: Pan 0.1°, Tilt 0.16°

Vertical limit switches, internally adjustable

ELECTRICAL

Power supply IN 24/230Vac, 50/60Hz

Standard Preset

Standard vertical and horizontal potentiometers

Potentiometer linear multiturns (10 turns)

Horizontal motor consumption 13W max

Vertical motor consumption 13W max

ENVIRONMENT

Indoor / Outdoor

Operating temperature: -20°C / +50°C (-4°F / +122°F)

Salty fog resistance

CERTIFICATIONS

CE EN61000-6-3, EN60065, EN50130-4

IP66/IP67 EN60529

BRACKETS AND ADAPTORS

NXWBPTH1 Heavy duty P&T Stainless Steel wall mount

RELATED PRODUCTS

NXM	Stainless steel housing
NXL	Stainless steel housing
NXJ	Stainless steel housing (to install with adapter OPTH200ADJB)
DTMRX2	Telemetry receiver 12 functions for NXPTH210 (no preset)
DTMRX224	Telemetry receiver 12 functions for NXPTH211 (no preset)
DTRX3	Telemetry receiver 17 functions for NXPTH210 e NXPTH211
DTRX324	Telemetry receiver 17 functions for NXPTH211

SPARE PARTS

DOTNXPTH Installation kit for NXPTH P&T

PACKAGE

Code	Unit weight		Package weight		Package dimensions (WxHxL)		Master carton unit
	kg	lb	kg	lb	cm	in	
NXPTH	15.0	33.1	15.5	34.2	24.0x32.0x24.5	9.5x12.6x9.6	-